

Post-Frame Construction Guide

Information for Design Professionals About Post-Frame

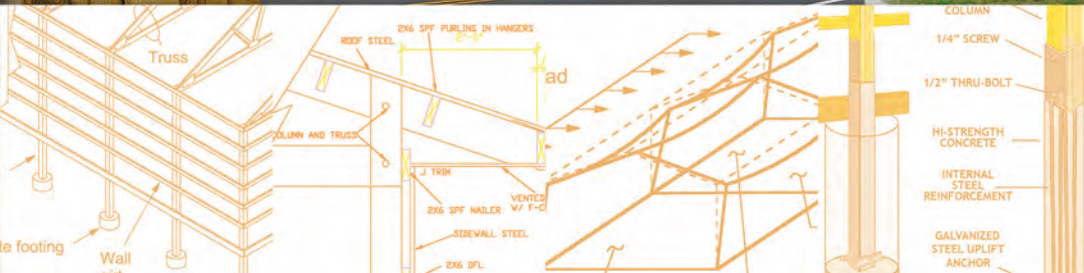

Connection with fasteners through bearing block & truss to post connection to meet load requirements

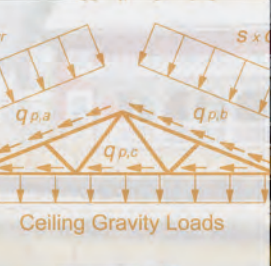
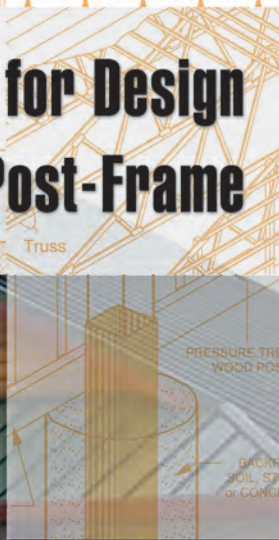
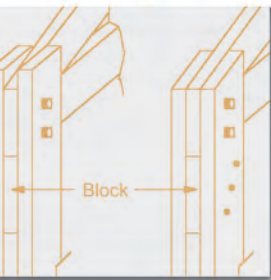

What is Post-Frame Construction?

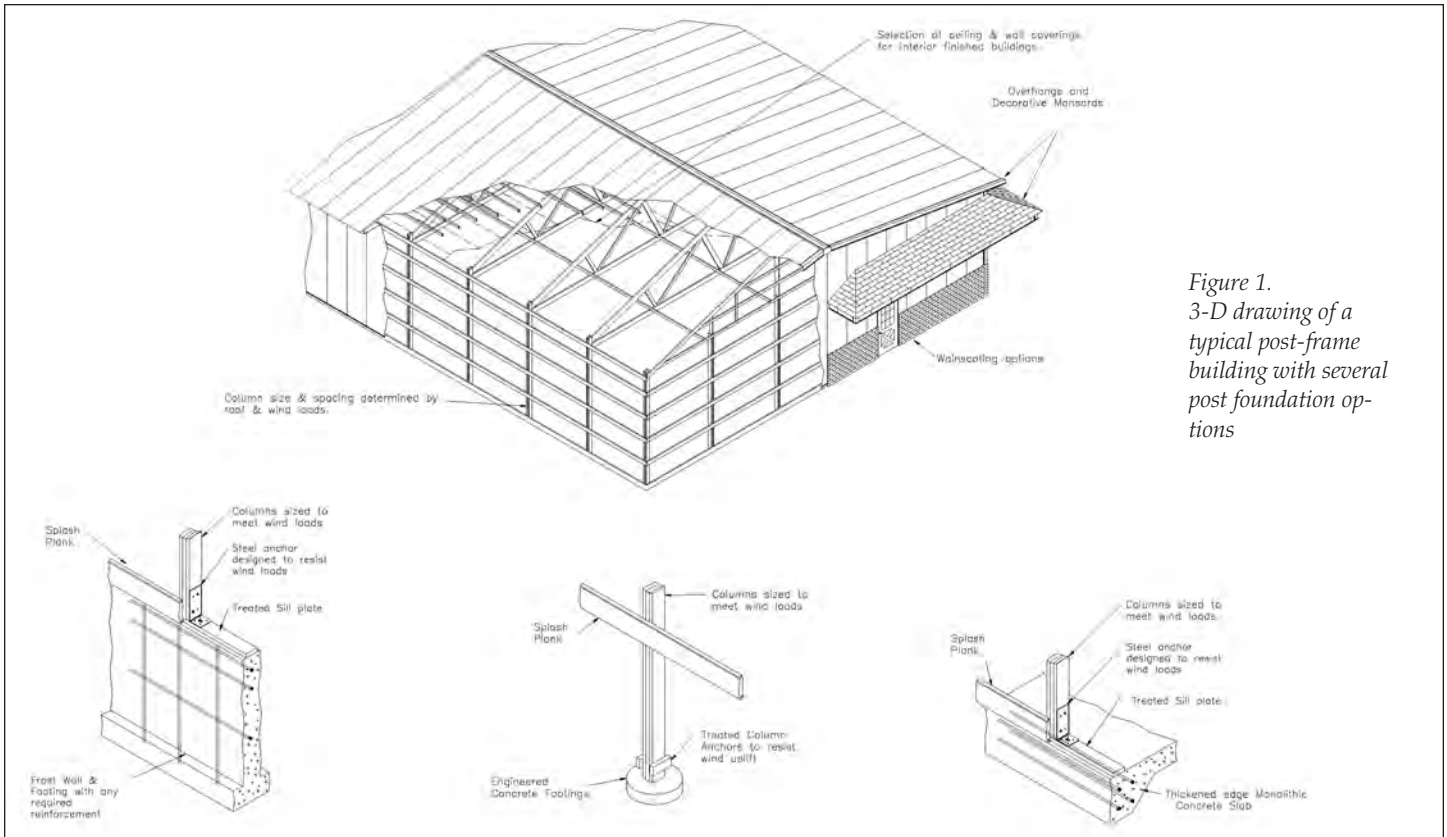

Figure 1. 3-D drawing of a typical post-frame building with several post foundation options

Post-frame buildings typically feature large, solid-sawn posts or laminated wood wall columns instead of wood studs, steel framing or concrete masonry. However, studs, steel and masonry elements are sometimes incorporated into post-frame structures to make unique “hybrid” buildings. Wall columns are either embedded into the ground or are attached to pre-cast or cast-in-place reinforced concrete piers, reinforced concrete foundation walls, or reinforced concrete thickened concrete slabs.

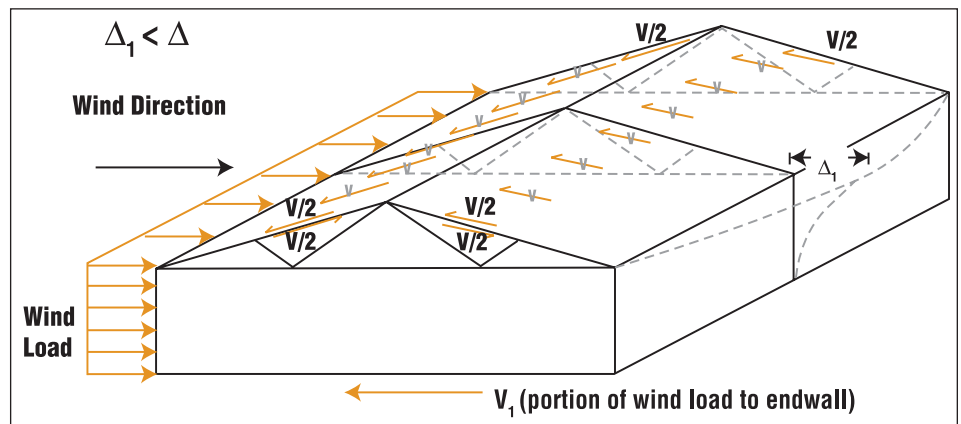
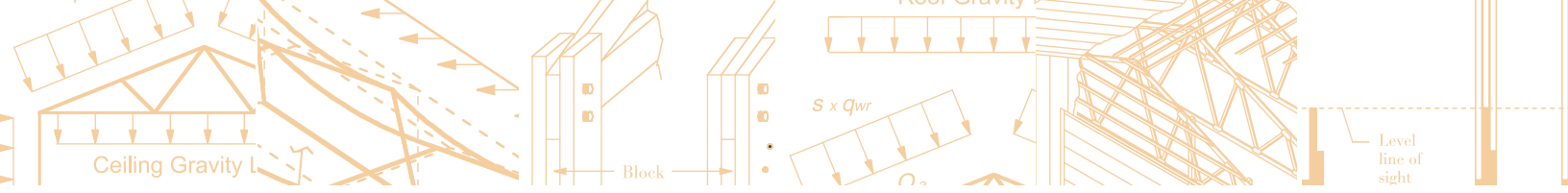

Figure 2. Post-frame building responses to rated loads with diaphragm action. (Δ_1 is eave deflection with diaphragm action; Δ is eave deflection without diaphragm action)

Post-frame buildings may utilize trusses, solid-sawn lumber rafters, or laminated lumber rafters to support roof loads. The roof framing may be affixed to each post or supported by a header. Horizontally-placed dimension lumber - roof purlins and wall girts - interconnect the posts

and trusses or rafters to form the basic frame. Exterior sheathing - commonly steel, OSB or plywood - provide lateral load resistance, creating a unique building diaphragm that makes the light wood

frame comparable in strength to light steel and concrete structures. Figure 1 shows a typical post-frame building system; Figure 2 illustrates the response of a Post-frame building system to diaphragm action.



Post-frame building systems were first developed in the 1930's as "pole buildings." They were constructed with pressure treated round wood posts and used primarily for agricultural facilities and small accessory buildings. In the late 1970's to mid 1980's, post-frame structures evolved into a finely-tuned engineered building system. Development and documentation of diaphragm design methodologies in the 1980's to mid 1990's improved the structural efficiency of post-frame building systems and launched the adoption of post-frame into the commercial and residential building sectors. Since then the development of glue laminated and nail laminated posts and the development of alternative post foundation systems have consolidated the adoption of post-frame building systems in the commercial and light industrial sectors.

An embedded pressure preservative treated wood post or reinforced concrete pier post foundation in post-frame buildings often replaces the continuous concrete foundation of conventional buildings. The in-plane shear strength and stiffness of the roofing materials transfer a significant portion of the lateral building loads through the roof and ceiling diaphragms to the end walls, thereby reducing the lateral load carried by the posts. Figure 3 shows the difference in the structural response of a post-frame with and without diaphragm action.

Post-frame accommodates a variety of foundation options, including concrete walls, concrete piers, thickened edges of concrete slabs and other products; see pages 8 and 12 for further details.

Post-frame buildings are durable, long-lasting, and adaptable to a wide variety of applications. Post-frame buildings are also exceptionally resistant to wind, snow and seismic loads. The entire structure works as a diaphragm to provide superior lateral load-resistance properties. If a design professional does not account for the diaphragm action provided by post-frame buildings, he or she may significantly over-engineer the building. Engineers who do not know how to account for diaphragm action may also mistakenly conclude that a post-frame building will not meet prescribed load criteria. Incorporation of diaphragm design concepts and construction details reduces post sizes and foundation embedment depth requirements for post-frame building systems.

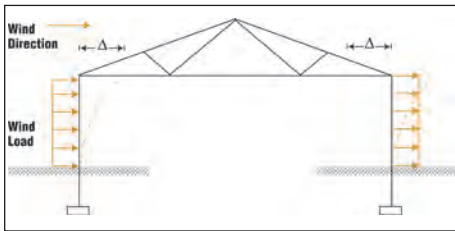

(a) Without diaphragm action.

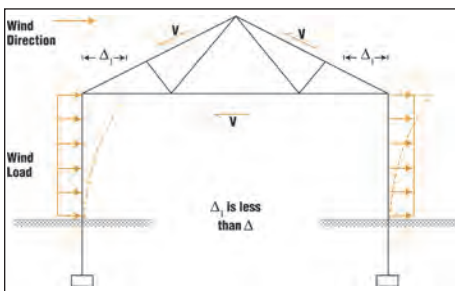

(b) With diaphragm action.

Figure 3. Cross section of a post-frame showing the response of post-frame (a) without diaphragm action and (b) with the in-plane lateral resistive forces provided by the roof diaphragm and ceiling diaphragm.



Figure 4. Post-frame building with stone and log facade.



Advantages of Post-Frame

Due to the application of modern structural engineering principles and testing methods, post-frame technology is recognized as a truly significant advancement in the centuries-old art of wood-frame construction. Post-frame is now the construction method of choice for any number of commercial, retail, industrial, residential, religious and public building needs.

Countless structures, including strip malls, convenience stores, restaurants, multi-family housing and office complexes, are now erected using post-frame methods. Schools, churches, banks, fire stations, airplane hangars, and many other kinds of buildings may also be designed and erected as post-frame structures. Many choose post-frame for homes, residential accessory buildings, garages, workshops and storage buildings.

Because of the nature of its design and many external façade options, post-frame may be customized to provide the look you want. Post-frame is an effective and versatile choice for building additions and remodeling projects. Entire buildings may be given a new look and/or function by integrating post-frame with existing structures.

Almost any type of exterior façade may be installed on a post-frame building. Steel siding, wood siding, stucco, brick, stone, and other products can be accommodated. Engineered wood siding products, architectural foam, thin-set brick, concrete, polyurethane or other composite materials that mimic brick or cultured stone can all be used on post-frame buildings.



Figure 6. Post-frame is ideally suited for retail and other commercial applications.



Figure 7. Post-frame is the most economical and versatile option for commercial and residential garages.



Figure 5. Post-frame is an energy-efficient choice for attractive residential dwellings.

The natural insulating properties of wood materials are superior to those of steel or masonry. Also, because the wooden posts are spaced farther apart than in stud-wall buildings, there are fewer interruptions in wall insulating materials. Since wall posts are typically 6 to 8 inches thick, post-frame buildings feature an exceptionally large wall cavity for ample insulation, thereby reducing heating and cooling costs throughout the year.

Post-frame design has proven so efficient and versatile that it has expanded from its agricultural building origins to the commercial and light industrial building sectors. Post-frame design is recognized by building codes and standards for many types of building applications.

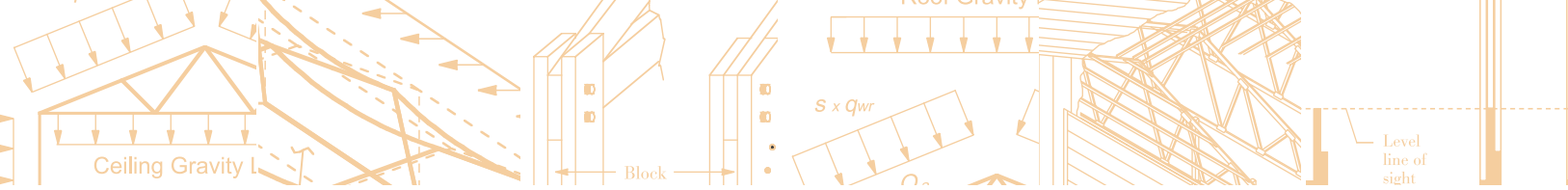

Figure 8. Mortarless brick and stone siding products allow design professionals new opportunities to create much more economical and energy-efficient buildings using post-frame techniques.

Post-frame buildings transfer loads to the ground through the posts, which are typically embedded in the ground or surface-mounted to a precast or cast-in-place concrete pier, concrete foundation wall, thickened floor slab or grade beam foundation. In addition, a number of protective cover systems have been introduced recently for enhanced protection of wood structural elements in contact with the ground.

People today are concerned about sustainability and environmental impact of construction. Post-frame buildings are among the most “green” buildings you can build, not only because of the renewable aspects of wood and the recyclable

nature of steel, but because efficient use of materials and long-term energy efficiency are superior compared to many other types of construction.

Post-frame buildings may be designed to meet the highest standards for quality and aesthetic beauty, and are a very efficient and economical choice for most low-rise building applications. Whatever interior or exterior look you prefer, post-frame can meet the challenge. For all kinds of buildings two to three or fewer stories tall, from small garages to commercial and industrial structures with clear-spans up to 100 feet or more, post-frame is an excellent choice due to its many inherent advantages.

Advantages of Post-Frame Construction

- Engineered Post-frame buildings are IBC code compliant.
- Post-frame buildings are durable and permanent when properly designed, constructed and maintained.
- Architectural designs that blend in with the local community are easily achieved.
- Engineered Post-frame buildings perform well during high winds or hurricanes.
- Engineered Post-frame structures perform well under seismic loading conditions.
- Site preparation is easy and post-frame structures are very adaptable to problem sites such as steep slopes and flood plains.
- Post-frame construction can easily continue during winter construction.
- Long-span trusses create large, open floor plans without the need for interior load-bearing walls, allowing greater design flexibility.
- Building system cost savings are realized in:

Materials – fewer, larger framing members optimize wall framing, thereby reducing the required framing materials

Labor – short construction time reduces construction costs

Construction equipment - wood post-frame buildings are easy to build because they can be constructed with readily available tools and equipment, so it's more cost effective

Lower interest costs - due to quicker erection.

Energy savings – the natural insulating properties of wood and large, uninterrupted wall and roof cavities help post-frame attain the highest R-values possible with minimal thermal bridging.



Post-Frame Building System Structural Components

The examples provided herein are not intended to mandate any specific practice.

Overview

The primary structural components of the post-frame building system are wood sidewall posts, post or foundation wall footers, post foundations, roof trusses or rafters, roof purlins, wall girts, wall and roof sheathing, connections, and secondary wind bracing (Figures 9 & 10). A description of typical details for each are presented in the following subsections. The examples provided herein are to illustrate concepts, not to mandate specific practices.

Wood Sidewall Posts

Sidewall posts are either solid-sawn timber, glued-laminated lumber or nail-laminated lumber. Glue-laminated and nail-laminated posts that are embedded into the ground have a pressure preservative treated section spliced to the bottom end (Figure 11 & 12). Posts of all types, when not in ground contact, often are not preservative treated. Glue- and nail-laminated wall posts are typically fabricated with 2x lumber. Typical post cross section sizes are nominal 4x6, 6x6, 6x8 or 8x8.



Figure 10. A typical post-frame building frame.

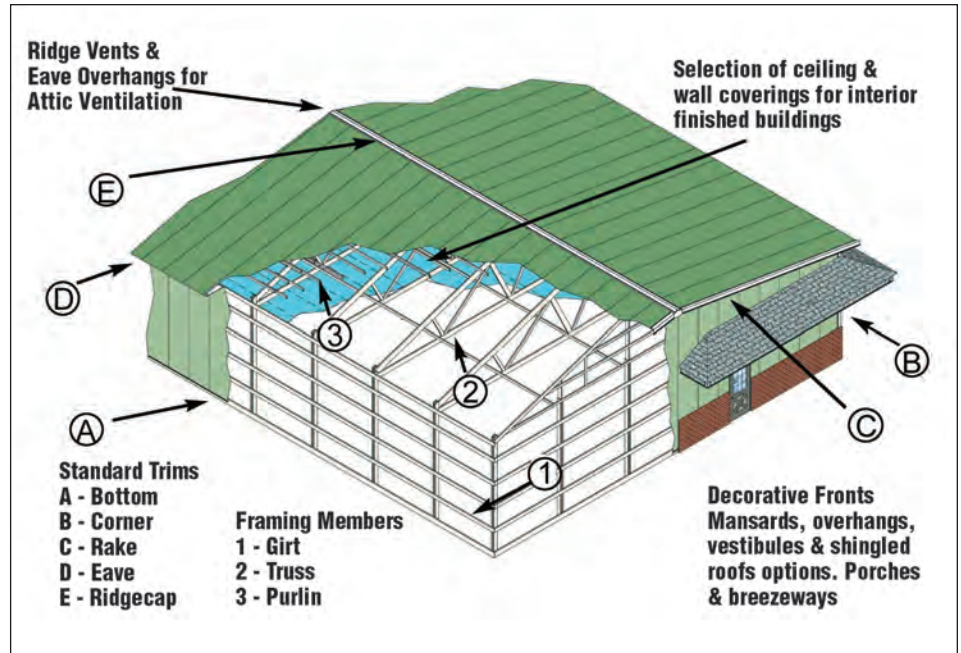

Figure 9. Illustration of typical post-frame building features.



Figure 11. Laminated columns often splice treated wood on the bottom end to untreated wood above grade.



Figure 12. Finger-jointed glue-laminated columns provide one of several good post options. Note treated wood spliced to the bottom end.

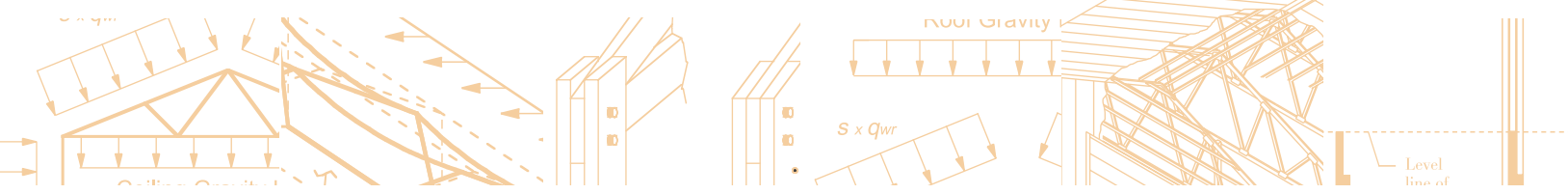

Post Footings

Post footings must provide resistance to gravity and uplift loads. Concrete footer pads, 18 to 24 inches in diameter and in some cases larger, typically resist gravity loads for embedded wood posts or piers. Footers are either cast-in-place or precast concrete placed at the bottom of the wood post, concrete pier or foundation wall. Foot-

ers under foundation walls are typically 18 to 24 inches wide. The mass of the foundation plus the mass of backfill above the portion of the footer attached to the post provides uplift resistance. Pressure preservative-treated wood cleats or concrete collars are typically attached to the bottom 12 inches of the embedded wood posts to increase uplift resistance (Figure 13).

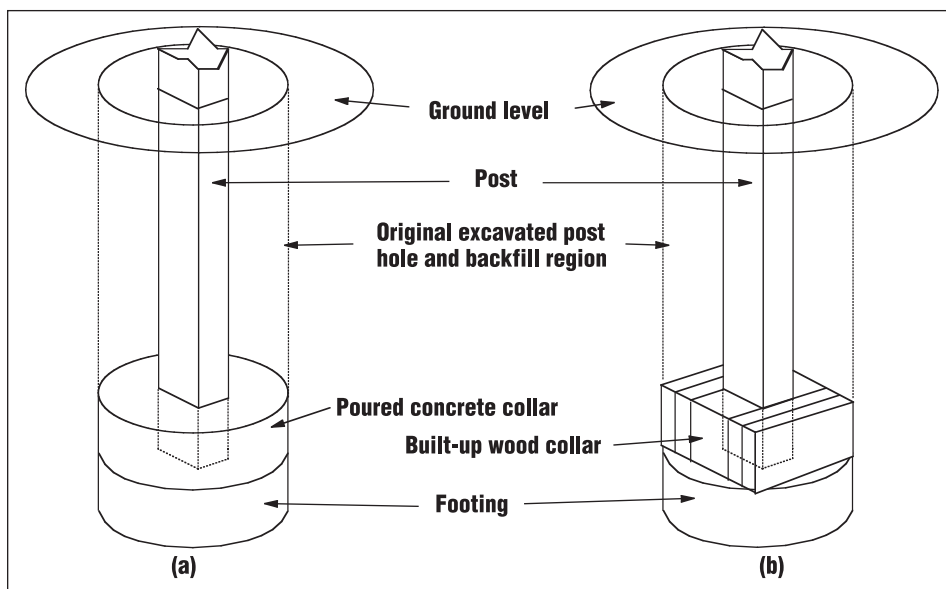

Figure 13. Embedded pressure preservative-treated wood post foundation with concrete footers and: (a) attached concrete collar and (b) attached pressure preservative-treated wood cleats.

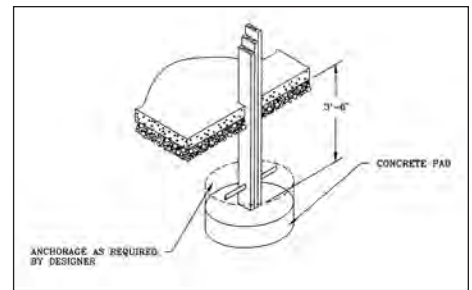

Figure 14. Treated posts may be embedded in the ground.

Post Foundation Options and Protective Barriers

Many post-frame buildings utilize a wood foundation comprised of pressure preservative-treated wood posts or laminated columns embedded directly into the ground (Figure 14). Post-frame buildings are also constructed on alternative post foundations, such as embedded precast or cast-in-place reinforced concrete piers (Figures 15, 16 & 17), concrete foundation walls (Figure 18), or thickened concrete slabs (Figure 19).

Continued on page 8



Figure 15. Cast-in-place concrete piers may be used for post-frame buildings.



Figure 16. Pre-cast concrete piers provide one of several foundation options unique to post-frame.



Figure 17. Pre-cast concrete piers with concrete floor.



Post-frame Building System Structural Components

Continued from page 7

Post-frame buildings may also utilize innovative products that provide alternatives to placing embedded wood posts directly in ground contact. Post-frame foundations may utilize enhanced wood treatment techniques and wood protection products developed specifically for post-frame buildings, such as plastic sleeves or boots (Figures 20 & 21).

Whether you choose the time-tested and proven method of embedding pressure preservative-treated wood directly in the soil or you select a concrete foundation wall or one of the other products developed specifically for post-frame foundation use, you can be confident that a post-frame building will provide a permanent building solution that complies with all applicable building codes.

The most common post foundations are either posts embedded in the ground, concrete pier foundations, foundation walls, or thickened edges of concrete slab. Pressure preservative treatment is required for all wood post foundations in ground contact. Protective barriers have been developed to enhance protection of wood foundation material in contact with the ground.

Embedded Posts

Many post-frame buildings use pressure preservative-treated wood embedded directly in the ground to form a post-frame foundation. Post-frame buildings that use properly treated wood products suitable for post-frame foundations have a long history of success.

Many people think all treated wood is the same. They are unaware that many types of wood commodities are available

that have been treated in various ways to meet specific purposes. Because decks and playground equipment are not generally considered crucial building structural elements, treated wood for those applications is not produced to the same specifications as for post-frame buildings. Properly treated and installed posts will ensure a post-frame building will last.

The USDA Forest Products Laboratory has conducted long-term tests in the harshest environments found within the continental U.S. Pressure preservative-treated test stakes in place since 1949 have shown no signs of failure. (Crawford, D.M.; Woodward, B. M.; Hatfield, C. A., Comps. Comparison of wood preservatives in stake tests. 2000 Progress Report. Res. Note FPL-RN-02. Madison, WI: U.S. Department of Agriculture, Forest Service, Forest Products Laboratory, P. 121). Modern

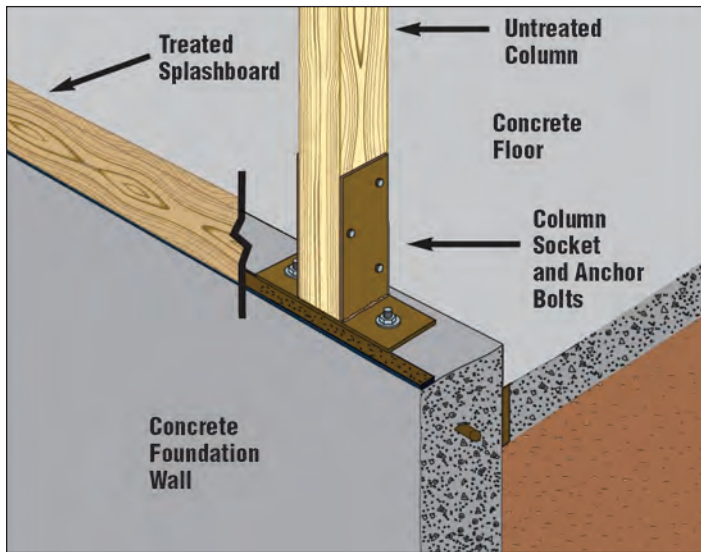

Figure 18. Typical detail of post-frame secured a top a concrete foundation wall.

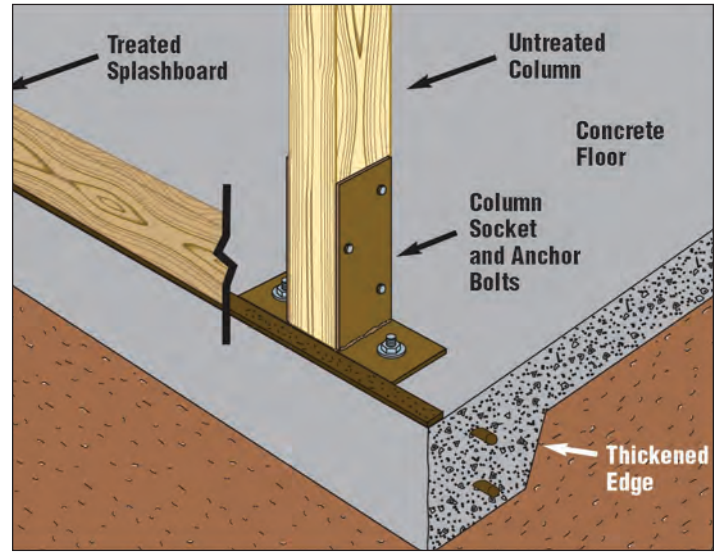

Figure 19. Typical detail of a post-frame building atop a thickened edge concrete foundation.

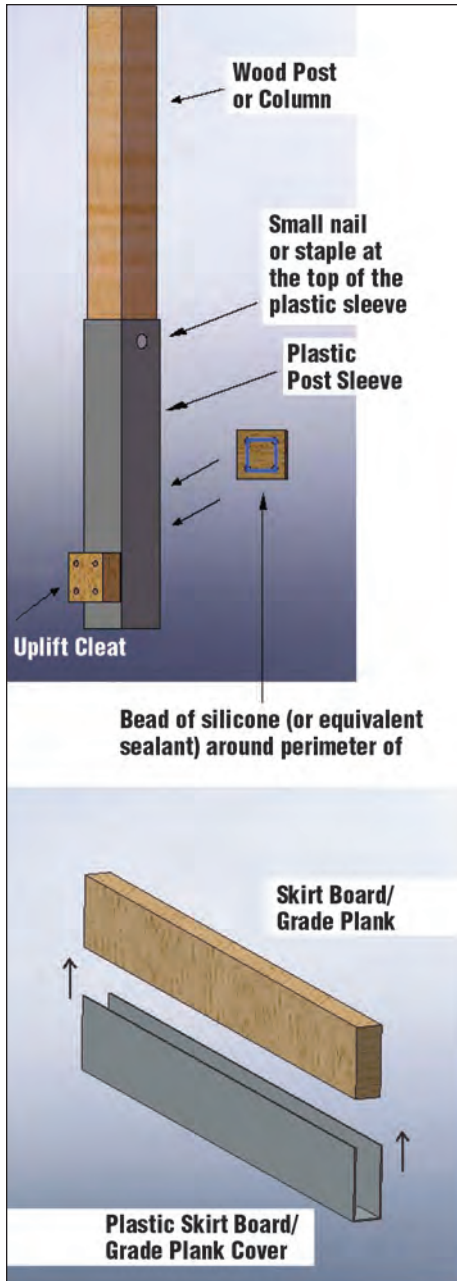
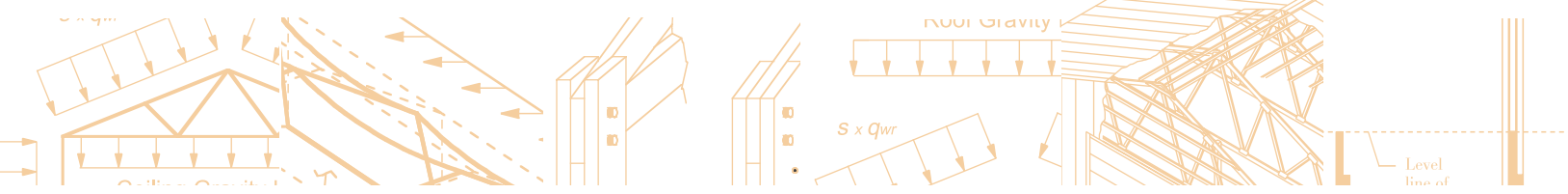

Figure 21. HDPE plastic barrier wood protection system

post-frame buildings typically use the improved formula CCA type C at retention level 0.60 pcf or one of the newer copper based preservative treatments at retention levels for structural in-ground contact applications (UC4B).

The American Wood Protection Association (AWPA) is the principle standards-writing body for wood protection in the U.S. Evaluation reports from one of several evaluation services, such as the ICC Evaluation Service (ICC-ES), may also set alternative criteria for code compliance of proprietary wood preservation systems. Various products have been adopted by AWPA and/or ICC-ES for post-frame building applications. Consult evaluation agencies, such as AWPA and ICC for further details.

Copper Chromated Arsenate (CCA) is acceptable to the EPA for post-frame building construction. CCA-treated solid-sawn posts larger than 5x5" and laminated columns of all sizes are allowed for post-frame buildings in any application, including commercial and residential applications

Continued on page 10

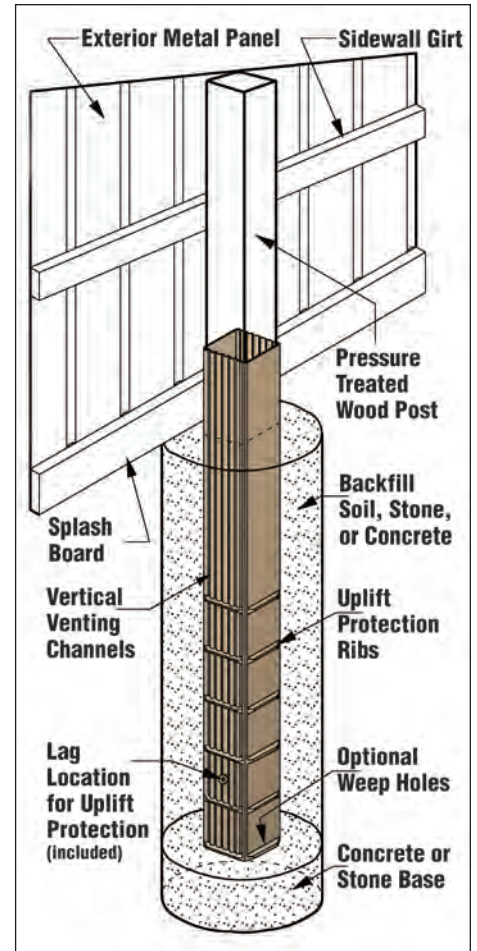

Figure 20. Blow-molded plastic barrier system



Figure 22. Post-frame is an excellent choice for strip malls and other retail buildings.



Post-frame Building System Structural Components

Continued from page 9



Figure 23. Post-frame allows high sidewalls and wide clear spans for mixed uses.

AWPA organizes standards according to its Use Category (UC) system. Wood for post-frame skirtboards should be treated to AWPA use classification standard UC4A (exterior, ground or freshwater contact in areas with low risk). Wood treated to UCA4 classification levels require both more and deeper preservative retention in the wood than do the use categories for wood decks, playgrounds and other common applications. Any portions of laminated columns and solid-sawn posts in ground contact should be treated to standard UC4B (exterior, ground or freshwater contact, severe environments, high potential for deterioration), for example, to a minimum retention of 0.60 pcf CCA.

An even higher level of retention may optionally be used for exceptionally harsh conditions or if additional protection is desired. If a customer requests an extra

level of wood protection, a builder may order wood treated to UC4C (exterior, ground or freshwater contact, very severe conditions or very critical structural components); or for example to 0.80 pcf CCA Kiln Drying After Treatment (KDAT). Other specialized foundation products may provide increased consumer confidence, but they are not required by the International Building Code.

The use of properly preservative treated materials – for example, a minimum of 0.60 CCA or to a minimum treatment classification of UC4B for portions of wood columns or posts embedded in the ground, a minimum treatment classification of UC4A for skirtboards, and a minimum treatment classification of UC3 for other dimension lumber less than 18 inches above ground level – is imperative to code compliance of post-frame structures.

IBC 2006, Section 2304.11.1 and 2 specifies that wood used above ground in the following locations shall be naturally durable or preservative-treated wood using water-borne preservatives in accordance with AWPA-U1 for above-ground use:

- Wood joists or bottom of wood floor closer than 18 inches and wood girders less than 12 inches above exposed ground.
- Wood framing members, including wood sheathing that rest on exterior foundation walls and are less than 8 inches above exposed ground.
- Slopes and sills on a concrete or masonry slab that is in direct contact with the ground.
- Ends of wood girders entering exterior concrete or masonry walls unless provided with a ½ inch airspace on top, sides and end.

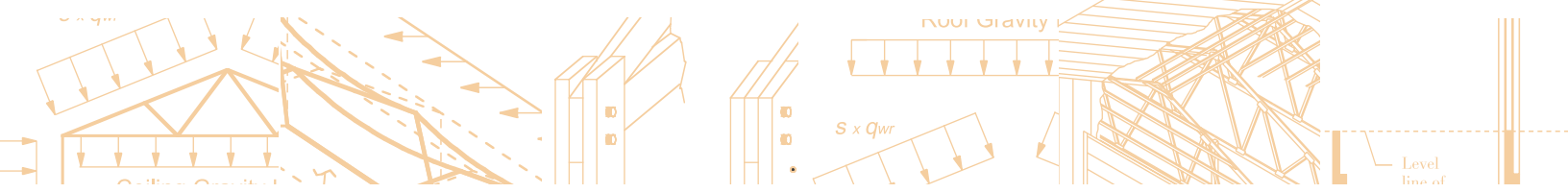

- Wood siding on exterior of building closer than 6 inches above the ground.
- Wood posts or columns supporting permanent structures and resting on concrete or masonry slab or footing that is in contact with the ground unless:
 - Post is supported by concrete piers or metal pedestals projected at least 1 inch above the slab and 6 inches above the exposed earth and are separated there by an impervious moisture barrier.
 - Post in enclosed crawl spaces or unexcavated areas located within building periphery and supported by a concrete pier or metal pedestal at least 8 inches above ground and separated there by an impervious moisture barrier.



Figure 24. Although any exterior finish may be used, steel siding and roofing are popular due to economy and maintenance-free durability.

IBC 2006, Section 2304.11.4 specifies that all wood elements in contact with the ground shall be naturally durable or preservative-treated wood using water-borne preservatives in accordance with AWPA-U1 for soil or fresh water use. (IBC 2006, p 434 & 435)

A quality builder will know manufacturer recommendations for fasteners and connectors to be used with treated wood and electrical barriers that prevent corrosion of metal panels. Stainless steel fasteners and panels with a thick galvanizing layer provide the best corrosion resistance.



Figure 25. Post-frame community center in an upscale housing development.

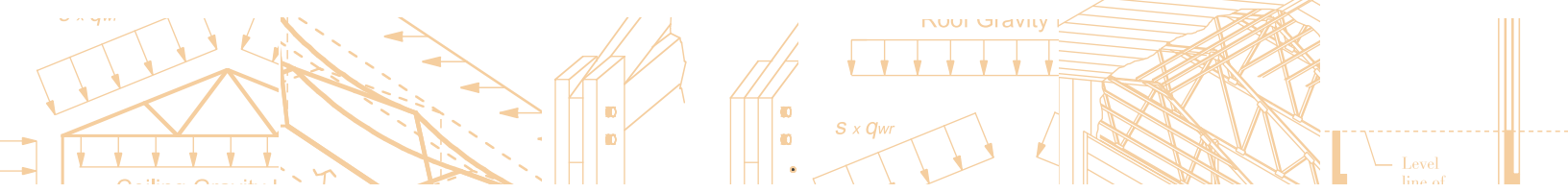

Post-frame Building System Structural Components

Continued from page 11

Reinforced Concrete Piers, Walls, Slabs

Besides embedding treated wood in the ground in accordance with IBC and AWPA guidelines, post-frame is readily adaptable to concrete slab and masonry foundations. Builders may use brackets or other fastening systems to install posts directly onto concrete foundations (Figure 26).

There are also products available that offer suitable options to avoid wood-to-ground contact. Although IBC and AWPA standards allow approved treated wood foundation materials to be in direct soil contact, some customers may choose one of the following foundation options that have been developed specifically for post-frame.

Pre-cast reinforced concrete piers, designed specifically for post-frame construction, consist of an embedded concrete column which may extend to 18 inches above the

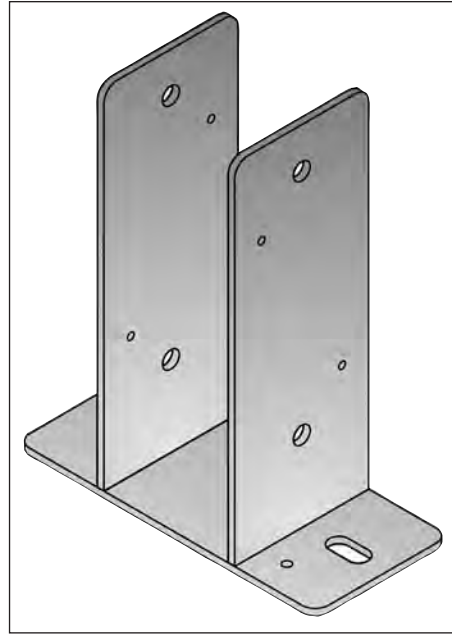

Figure 26. Example of a drill-set post anchor that may be affixed upon a concrete slab or masonry foundation wall.

groundline. A steel anchor bracket, for attaching a solid-sawn post or laminated column, is mounted to the top of the pier (figure 27). This foundation is usually factory fabricated and shipped to the site

Cast-in-place (poured-in-place) concrete pier systems are similar to pre-cast concrete piers except they are fabricated on-site. Once the anchor brackets are placed and the concrete has set, the wood posts/ columns are attached to the foundation pier (Figure 28).

Concrete foundation wall systems for post-frame buildings typically have a 6 or 8 inch wide continuous concrete wall that extends below grade to the footer. The post-frame is attached directly to the top of the foundation wall with properly designed connection hardware (Figures 18 & 26.)

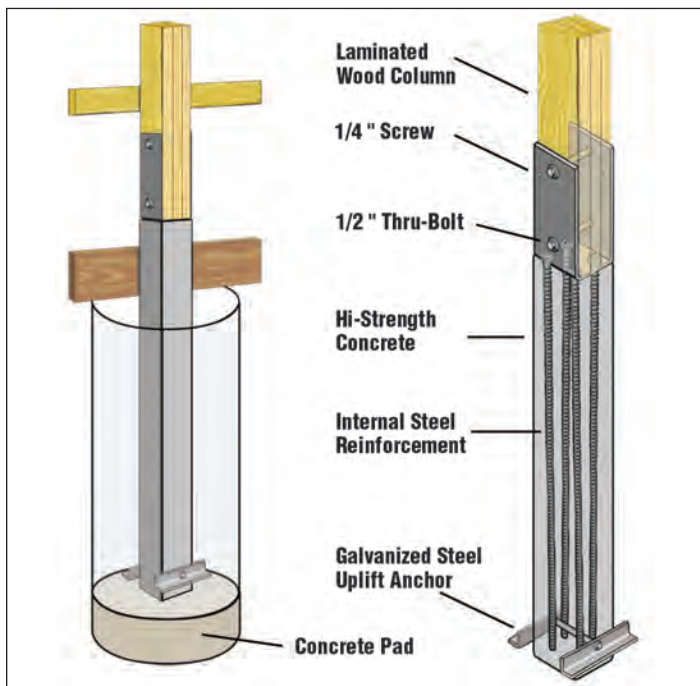

Figure 27. Pre-cast reinforced concrete post-frame foundation piers.

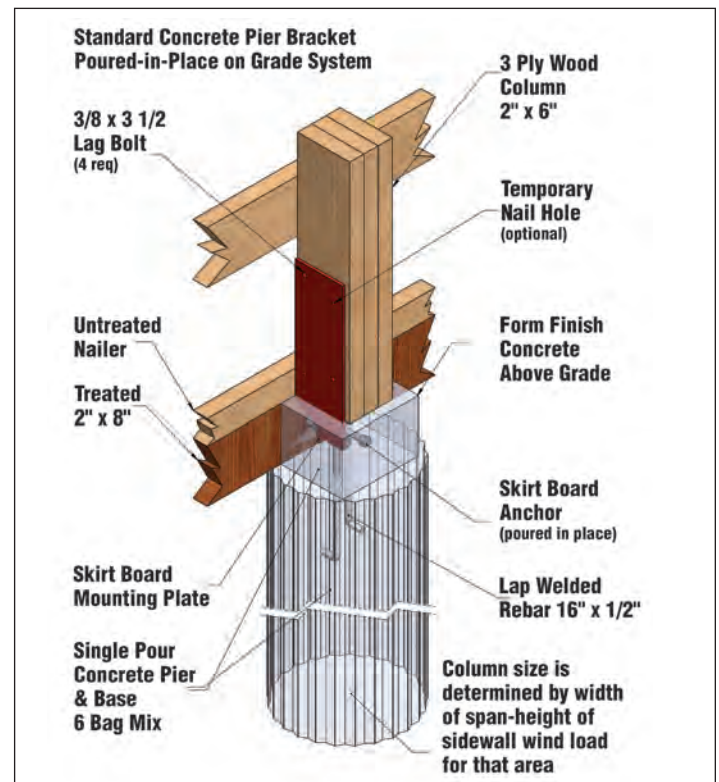

Figure 28. Cast-in-place concrete pier system



Thickened concrete slab post-frame foundation systems are an integral part of the building's floor slab. The post-frame is attached directly to the thickened, reinforced concrete edge of the floor slab with properly designed hardware (Figures 19 & 26).

Protective Cover Systems

Blow-molded plastic barrier systems for enhanced protection of copper-based chemical-treated wood posts or laminated columns provide moisture and insect protection from (Figure 20) the footer to above finished floor grade.

HDPE plastic barrier wood protection systems for enhanced protection of copper-based chemical-treated wood posts and laminated columns form a plastic sleeve with an enclosed bottom to cover the embedded portion of posts or columns (Figure 21).

Polyethylene post sleeve and footing forms enclose the embedded portion of solid-sawn or laminated post to provide enhanced protection of copper-based chemical-treated post-frame foundations.

Asphalt and polyethylene based barrier wrap protection systems, which use shrink-wrapped polyethylene over posts that have been pre-coated with bitumen.

Designers and builders should check for code compliance with the AWPA Standards or an ICC, or equivalent, evaluation report.



Figure 29. Post-frame retail facility with large interior clear-spans and ample room for show rooms and mechanic's shop.



Figure 30. Post-frame garden center featuring retail areas, offices and work areas.



Post-frame Building System Structural Components

Continued from page 13

Roof Framing (Trusses and Rafters)

The most common roof framing for post-frame building systems consists of pre-engineered metal-plate connected wood trusses. Trusses are typically spaced 4 to 8 feet on center, and may span more than 100 feet. On wider truss spacings and in locales with higher snow loads, the trusses may be doubled. Truss spacings are often the same as the sidewall post spacings, but sometimes are less than post spacings. If truss and post spacings are the same, trusses are connected directly to the top of the sidewall posts; when truss spacings are less than post spacings, the trusses are attached to headers which are then attached to the tops of the sidewall posts.

For shorter clear spans, 2x solid-sawn or structural composite lumber (SCL) rafters are used in place of roof trusses. These roof rafters are typically spaced 18 to 30 inches on center. For larger clear spans

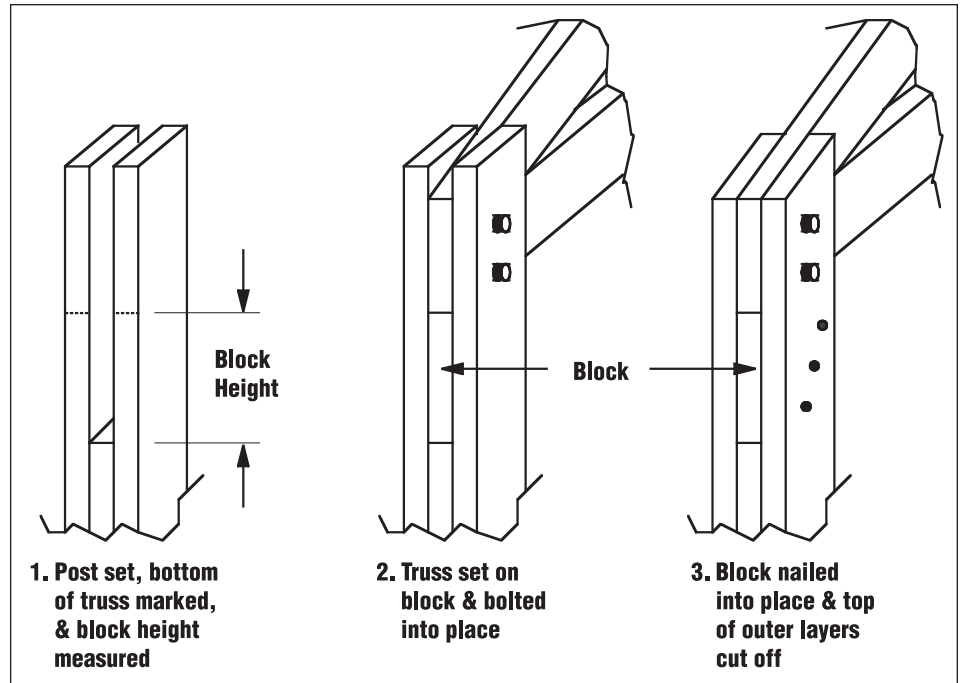

Figure 31. Typical truss to nail-lam post connection.

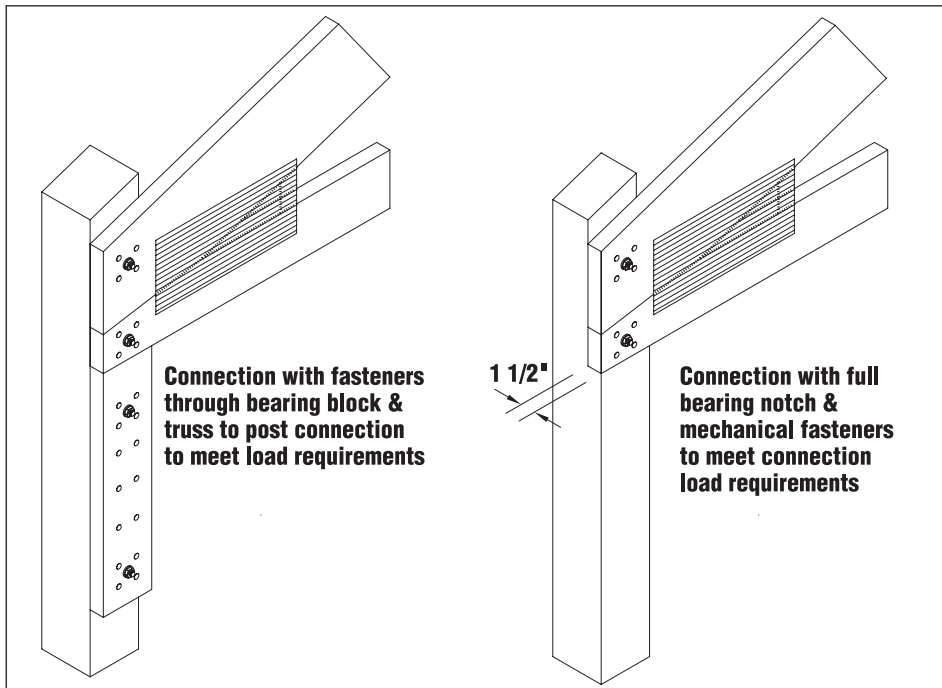

Figure 32. Typical truss to solid sawn post connection.

and wider rafter spacings, the 2x rafters are typically replaced with wider SCL or with glue-laminated lumber rafters.

Post to Truss and Header to Roof Framing Connections

Post-frame buildings are designed in many different ways. Builders, suppliers and design professionals may exercise considerable creativity to create new designs for various connections. Typical post to truss or rafter connections are shown in (Figures 31 & 32) for solid sawn or nail-lam wood columns.

Trusses or rafters are typically attached to the posts when post and truss/rafter spacing are equal. When unequal, the roof framing is attached to solid sawn, SCL, or glue laminated headers (Figures 33 & 34).

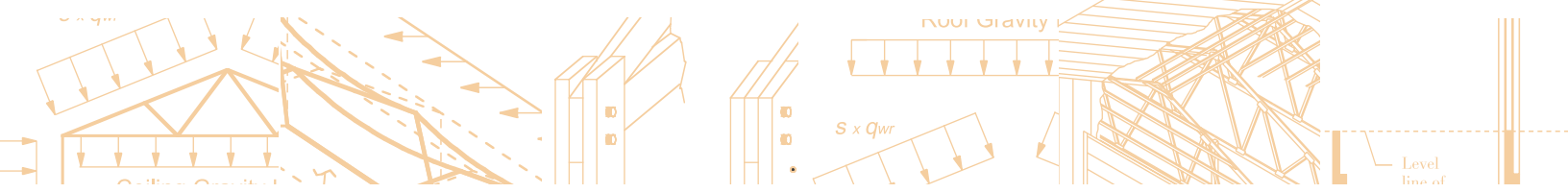

Headers and Header to Post Connections

Header beams may or may not be necessary, depending on post and truss spacing. When truss and wall post spacing is equal, header beams are not necessary because trusses are directly supported by the post. Headers are either one or two wood members attached to the side(s) of the top of the wood columns. Header materials are either solid sawn lumber, glulam lumber or structural composite lumber. Headers may span one or multiple posts depending upon bay length and header material. Typical header to post and truss to header connections are shown in Figures 33 & 34.

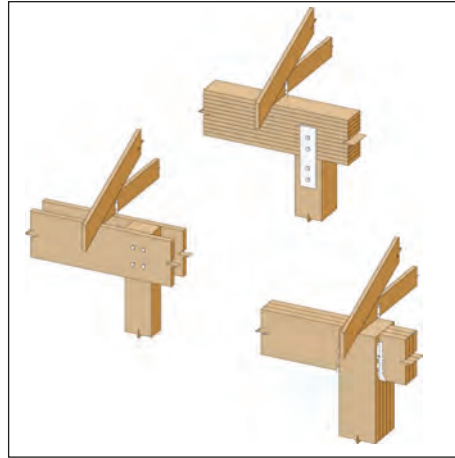

Figure 33. Typical truss to solid sawn header and truss to post connections.



Figure 34. Post to Glu-lam or SCL header and header to truss connection.



Figure 35. Typical Post-frame roof framing showing engineered metal plate connected wood trusses, roof purlins affixed atop trusses on edge and lower chord stiffeners.

Purlins

Purlins are 2x4 or 2x6 dimensional lumber members that span between main roof members to provide framing for sheathing material attachment. Their functions are to:

- Resist gravity loads (e.g. sheathing dead load and snow loads).
- Resist secondary wind uplift loads.
- Laterally brace rafters or truss top chords.

Purlins can be placed flat-wise or on edge across roof framing members, or installed between them. See Figure 35 for typical roof purlin framing. It is important that purlin spacing be specified by the truss designer because purlins function as an integral part of the truss' permanent lateral bracing. Connection detailing is also very important for proper purlin installation. Purlins can be placed on a designed ledger or in hangers so the top of the purlin is flush with the top of the truss or rafter for easier sheathing installation.



Post-frame Building System Structural Components

Continued from page 15

When diaphragm action is utilized to carry wind or seismic loads to the end walls (shear walls), the purlins must be spliced or overlapped to provide a continuous load path over the entire building length. Purlins are very easy to install because they are light framing members. This helps speed up the roof framing process.

Wall Girts

Girts are typically 2x4 wood members attached horizontally to the outside face of post-frame columns to support the wall sheathing and to carry wind loads. They also provide lateral support for the columns to resist buckling in the plane perpendicular to the post-frame. Wall girts speed construction due to their horizontal orientation, and eliminate the need for the top and bottom plates of standard stud walls.

Sheathing

Post frame sheathing often consists of 26 to 29 gauge ribbed metal cladding attached directly to the roof purlins and wall girts. Structural wood panel products are also used in some post-frame applications. Plywood or oriented strand board (OSB) may provide support for almost any type of exterior siding product.

Bracing

Wall girts provide lateral bracing for wall posts and columns and support wall sheathing. Roof purlins provide lateral bracing for roof rafters or for upper chords of trusses.

Permanent bracing is used to make the truss component an integral part of the roof and building structure. Permanent bracing includes lateral, diagonal, and cross bracing.



Figure 36. Many mistake this post-frame building for a less thermally-efficient brick building.



Figure 37. A post-frame veterinary facility.

Temporary bracing is used during erection to hold trusses in place until permanent bracing, purlins, sheathing, and ceilings (if used) are installed. Proper erection bracing will assure that trusses are installed properly, and create a safe working environment.

Building designers are responsible for the proper design of permanent bracing. Erection contractors are responsible for the proper installation of temporary and permanent bracing.

For additional guidance on handling, erecting, and bracing wood trusses, contact the Truss Plate Institute (TPI) at 608/833-5900 or the Wood Truss Council of America (WTCA) at 608/274-4849, or visit www.woodtruss.com.

Alternatives

Post-frame construction can also be integrated into stud-wall construction, depending on client needs. The construction elements may be manufactured on the job site or in a wall-panel plant.

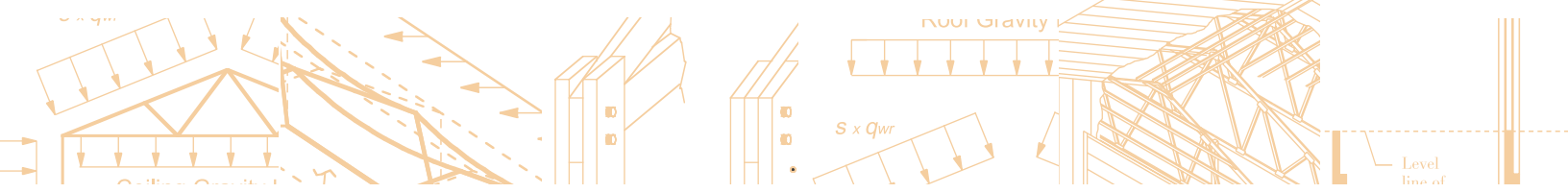

Fire Performance

With compartments and an efficient protection system, such as sprinklers, fires can be localized and more easily suppressed. Dimension lumber, metal plate connected trusses, glued-laminated timbers and other structural wood products have a long history of solid fire endurance performance.

The three major source documents for dimension lumber and truss fire endurance assemblies are: the Fire Resistance Design Manual published by the Gypsum Association; the Fire Resistance Directory published by the Underwriters Laboratories, Inc. (ULI); and the Uniform Building Code Table 43-C. The assemblies in these documents range in performance from 1 hour to 2 hours, providing flexibility for any project need.

Proprietary fire endurance assemblies and fire retardants also exist. For more information on these, contact TPI or WTCA. The National Frame Building Association (NFBA) has constructed and tested a 1-hour rated firewall assembly. Builders often successfully modify this 1-hour assembly to achieve inspector approval of a 2-hour firewall rating by applying additional sheets of drywall. For more information visit www.nfba.org.

Post-frame buildings typically feature steel cladding that is very resistant to fire. Wood is flammable, although it is not as combustible as some other building materials. Steel, masonry and other products that are fire-resistant may also see structural failure in building fires. Like other types of buildings, post-frame buildings may be erected to provide effective fire resistance in accordance with building code requirements.

Sprinklers

Post-frame easily adapts sprinkler systems and other forms of fire protection. Depending on the importance factor of the building and how it will be used, fire suppression systems may be recommended.

The primary sprinkler installation standard used for commercial/industrial buildings is Installation of Sprinkler Systems, NFPA 13, which is also adopted by the model building codes. For more detailed information on sprinklers and their installation, contact NFPA at 617/770-3000, the National Fire Sprinkler Association at 914/878-4200, or a local sprinkler installation contractor.



Insurance Considerations

The cost of insuring a building is another major construction consideration, particularly in commercial buildings. The insurance industry uses the following criteria to evaluate the loss potential of buildings:

1. Occupancy load (type of business)
2. Exposure (possible risk of loss)
3. Construction type (wood, steel, or concrete)
4. Special hazards
5. Protection (sprinklers, fire alarms)

Occupancy loads and exposure are the two primary decision factors for insurance companies because they will most influence the risk of loss. The construction type (e.g. post-frame, steel-frame, etc.) portion of the rate does not typically vary by more than 5% from the most combustible to the least combustible designation for larger commercial/industrial buildings, based on research performed in the Midwest.

In addition, buildings of three stories or less are often underwritten using a global or class rate system which does not even differentiate by construction type. Increased building protection from sprinklers, periodic security checks, fire alarms connected to the fire department, etc., can dramatically lower insurance rates because of the reduced possibility of large fire losses.

Insurance ratings are often building-specific and are based primarily on the statistical loss experience and loss severity that insurance companies have found for the building type being constructed in a specific geographic region. In some cases, insurance companies use the global Insurance Services Office (ISO) loss statistics. In other cases, they use their own loss experience. Both influence the ultimate insurance rate quoted.

All of this means the cost of insuring a post-frame building should be comparable to the cost of insuring a steel-frame building. The key to getting the best insurance rate is to get several bids from different insurance brokers using different insurance companies. It is also helpful to add fire detection and protection systems to get the lowest possible rates.



Code Compliance

Post-Frame is code accepted and compliant with applicable building regulations. Pertinent standards include:



American Wood Council

The American Wood Council's Design for Code Acceptance document "DCA5 – Post-Frame Buildings" summarizes and documents post-frame code compliance.



International Building Code

The International Building Code recognizes and approves post-frame construction in accordance with American Society of Agricultural and Biological Engineers' engineering practice standards EP 486 and EP 484.2 in Section 2306.1 (Allowable Stress Design) since adoption of the 2003 IBC. The IBC recognizes and approves post-frame construction in accordance with the referenced standards.



ASAE EP486.1, Shallow Post Foundation Design

This engineering practice created through a consensus process by the American Society of Agricultural and Biological Engineers (ASABE, formerly ASAE) presents the engineering basis for determining the depth of embedment for sidewall posts in post-frame buildings. It presents a rational basis for the required lateral and uplift capacity for the embedded post and for designing the foundation for a post-frame building.

ASAE EP484.2, Diaphragm Design

This presents the rational engineering basis for diaphragm design of post-frame buildings in a format suitable for acceptance by architects and engineers, referenced from IBC section 2306.1.

ASAE EP 558, Load Tests for Metal-Clad Wood-Frame Diaphragms

This engineering practice establishes the test procedures and the data analysis procedures for determining the in-plane shear strength and in-plane shear stiffness of metal-clad, wood-framed structural diaphragms typically used in post-frame buildings and other sheathing in accordance with their performance characteristics. The in-plane shear strength and stiffness are required inputs for the engineering practices presented in ASAE EP484.2.

ASAE EP559, Mechanically Laminated Columns

This engineering practice presents the rational basis for determining the structural strength and stiffness of mechanically laminated columns used in many modern post-frame buildings.



American Wood Protection Association

The American Wood Protection Association's standards and EPA documents confirm the suitability of using properly treated building posts in ground contact for permanent edifices. AWPA documents specify treatment of posts and various other lumber products installed at or below grade for buildings in the use category system: "User Specification for Treated Wood Products." AWPA specifies UC4A for above-ground uses such as post-frame skirtboards and UC4B for "building poles and permanent wood foundations" embedded within the ground. These and EPA documents confirm the suitability of using properly treated building posts in ground contact for permanent edifices.



American Society for Testing Standards (ASTM)

ASTM F1667 - Table 45, Type 1, Style 30 Post-Frame Ring-Shank Nails sets production standards for threaded hardened nails, and is referenced in the National Design Specification (NDS), published by the AWC. NDS establishes the technical specifications for the dimensions, tolerances and materials for the manufacture of fasteners. Post-Frame Nails have exceptional withdrawal resistance characteristics. This unique fastener has been thoroughly tested and is recognized by these construction industry standards.



National Frame Building Association

NFBA has assembled all pertinent engineering information from codes and standards into the *Post-Frame Building Design Manual*, the only current and complete published reference of its kind on how to properly design and engineer post-frame buildings. www.nfba.org

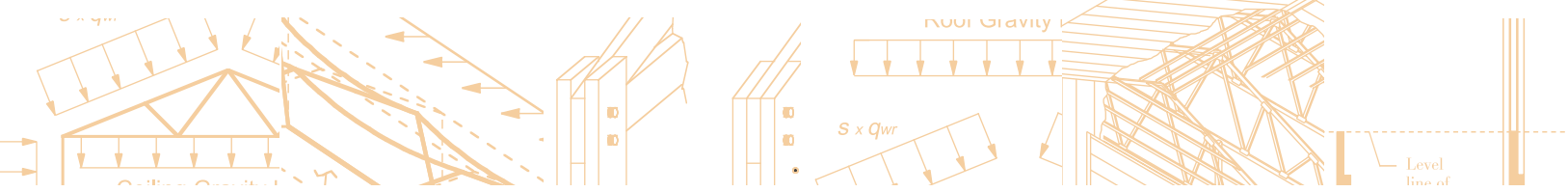

Post-Frame Design-Related Documents

From the National Frame Building Association (NFBA)

www.nfba.org

- Post-Frame Building Design Manual
- Fire Test Manual
- 1996 Diaphragm Test Kit
- Post-Frame “Beautiful Buildings Brochure”
- Framing Tolerances Standard
- Metal Panel & Trim Installation Tolerances Standard
- “Spotlight on Architecture: Post-Frame Buildings” Video

From the American Society of Agricultural and Biological Engineers (ASABE) - www.asabe.org

- EP484.2 Diaphragm Design of Metal-Clad, Wood-Framed Rectangular Buildings
- EP558 Load Test for Metal-Clad, Wood-Framed Diaphragms
- EP559 Design Requirements, and Bending Properties for Mechanically Laminated Post
- EP486.1 Shallow Post Foundation Design
- Paper #01-4012 Uplift Resistance of Post Foundations

From the American Society of Civil Engineers (ASCE)

www.asce.org

- Minimum Design Loads for Buildings and Other Structures, ASCE/SEI 7

From the American Wood Council (AWC) – www.awc.org

- National Design Specification (NDS) for Wood Construction
- DCA5 – Post-Frame Buildings

From the American Wood Protection Association (AWPA)

www.awpa.com

- AWPA U-1 Use Category System: User Specification For Treated Wood

From the International Building Code (IBC)

www.iccsafe.org

- Section 2306.1 (Allowable Stress Design)

From Wood Truss Council of America (WTCA)

www.woodtruss.com

- BCSI-B1 Guide for Handling, Installing and Bracing of Metal Plate Connected Wood Trusses
- BCSI-B2 Truss Installation & Temporary Bracing
- BCSI-B3 Web Member Permanent Bracing/Web Reinforcement
- BCSI-B4 Construction Loading
- BCSI-B5 Truss Damage, Jobsite Modifications & Installation

Errors

- BCSI-B6 Gable End Frame Bracing
- BCSI-B7 Temporary & Permanent Bracing for Parallel Chord Trusses
- BCSI-B9 Multi-Ply Girders
- BCSI-B10 Post-frame Truss Installation & Bracing
- BCSI-B11 Fall Protection & Wood Trusses
- ANSI/TPI National Design Standard for Metal Plate Connected Wood Truss Construction (TPI 1)
- 1-03 Guide to Good Practice for Handling, Installing & Bracing of Metal Plate Connected Wood Trusses
 - a) Commentary for Permanent Bracing of Metal Plate Connected Wood Trusses
 - b) Informational Series of Documents Titled “Truss Technology in Building”

From Universities with Inter-Library Loan programs:

- Walker, J. N. and F. E. Woeste, Editors. 1992. Post-frame building design. ASAE Monograph No. 11, ASAE, St. Joseph, MI. – Provides an in-depth and complete discussion of modern post-frame design for a full understanding on an engineering level.

NOTE: Complete information on how to properly engineer a post-frame building is covered in the *Post-Frame Building Design Manual*, which may be purchased from the National Frame Building Association. For more information, call 800/557-6957 or visit www.nfba.org.

The materials and information contained in this brochure have been gathered from a variety of sources and from qualified individuals, and are therefore deemed reliable. The material is not guaranteed and is not necessarily a complete statement of all available data. Conclusions are based solely upon our best judgment, analysis of technical factors and individual information sources.

Because the Association has no control over quality of workmanship or the conditions under which engineered wood products are used, it cannot accept responsibility for product performance or designs as actually constructed. Because product performance requirements vary geographically, consult your local architect, engineer, or design professional to assure compliance with code, construction, and performance requirements. The National Frame Building Association, its principals and members, accept no liability for any errors or omissions herein, or for any resulting injury or damage caused by their use in the design or engineering of any particular structure.



Published by the
National Frame Building Association
4700 W. Lake Ave.
Glenview, Illinois 60025
www.postframeadvantage.com